

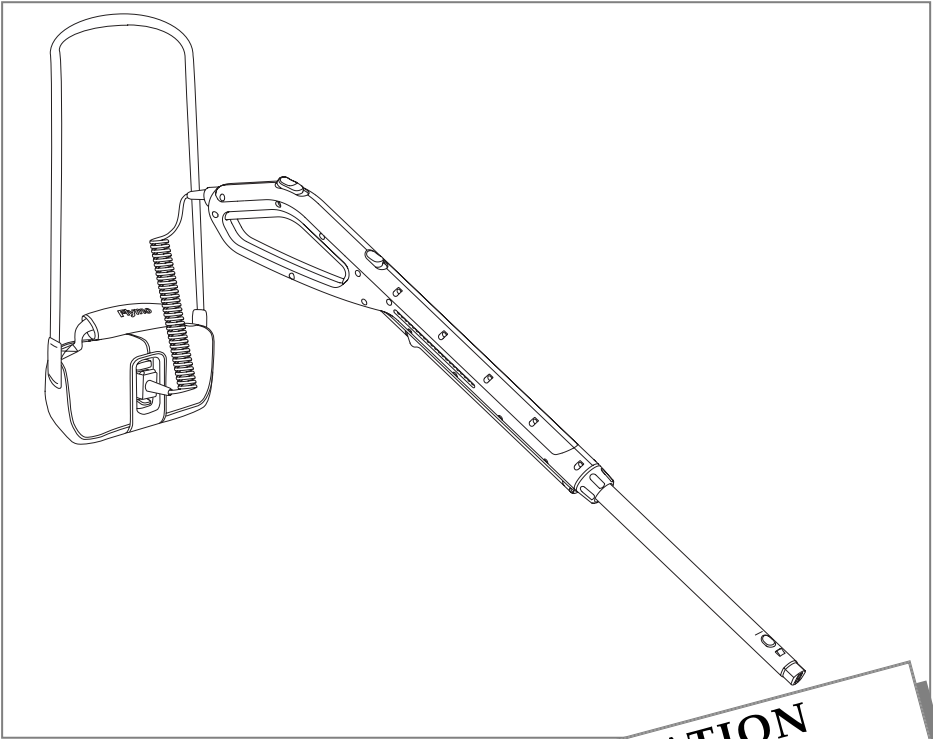

Sabre Power Pack



IMPORTANT INFORMATION
Read before use
& retain for future reference



WARNING

Husqvarna Outdoor Products
Aycliffe Industrial Park
NEWTON AYCLIFFE
Co.Durham DL5 6UP
ENGLAND
Telephone - (00) 44 1325 300303 Fax - (00) 44 1325 310339
UK Customer Helpline - 01325 300303 Fax - 01325 310339

Our policy of continuous improvement means that the specification of products may be altered from time to time without prior notice.

5107420-01



For all customer enquiries or for replacement parts, contact:-

☎ 01325 300303

🖱 www.flymo.com



customer.services@husqvarna.co.uk

Carton Contents

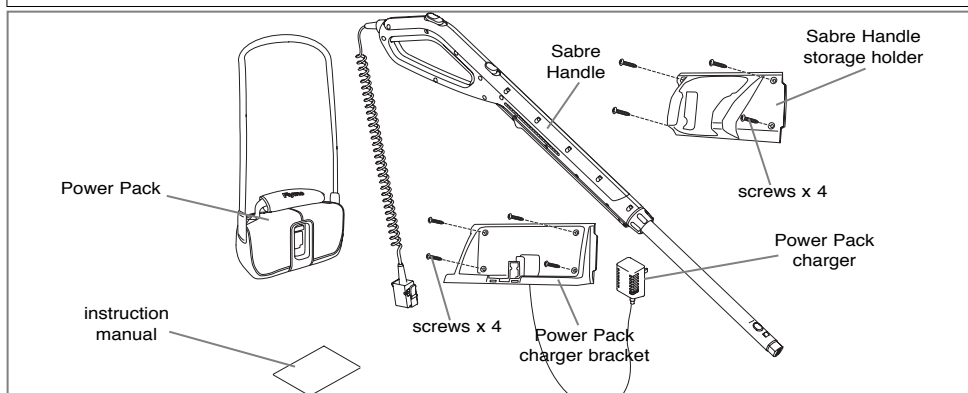

IMPORTANT! Please check the contents of the carton are correct **BEFORE** assembling your new product. **IF ANY PARTS ARE MISSING CONTACT:-**

Husqvarna Outdoor Products Customer Service Department direct
Telephone : 01325 300303, Fax : 01325 318193

Safety



If not used properly this product can be dangerous! This product can cause serious injury to the operator and others, the warnings and safety instructions must be followed to ensure reasonable safety and efficiency in using this product. The operator is responsible for following the warning and safety instructions in this manual and on the product.

Explanation of Symbols on your product



Warning



Read the user instructions carefully to make sure you understand all the controls and what they do.

- Always charge the Power Pack indoors and store in a cool dry place - out of the reach of children.
- Use only the charger provided with your unit. Use of any other charger could permanently damage the Power Pack.
- Use the charger with standard domestic household electrical outlets only.
- Do not abuse the charger or charger cord.
- Do not use the charger if the charger or charger cord is damaged.
- Use the charger indoors only.
- Do not use the charger outdoors.
- Do not charge the Power Pack or use the unit in an explosive or corrosive environment. Avoid areas where flammable liquids or gases are present to avoid creating a fire or explosion.
- Do not attempt to repair the unit including the Power Pack.
- Do not incinerate or mutilate the Power Pack. Batteries contain hazardous chemicals. Dispose of properly.

Power Pack

Power Pack Care

- If over a period of time the Power Pack quickly runs down after a full 24 hour charging period, a replacement Power Pack is needed.
- There will be some charge present in the Power Pack but to ensure maximum running time, recharge your Power Pack for 24 hours before use.
- Permanent connection to the charger in a well ventilated area will automatically keep your Power Pack fully charged ready for use.
- To prevent permanent Power Pack damage, never store in a discharged condition.
- Contact your local approved service centre/dealer/distributor for a replacement Power Pack and for safe disposal of your old Power Pack.
- Battery**

24 Volt 4.5 Amp/Hour "High Power"
Sealed for Life No maintenance required

- IMPORTANT**
DISPOSE OF YOUR OLD POWER PACK SAFELY
DO NOT CUT OPEN, BURN OR INCINERATE.

Power Pack Replacement

Your Power Pack is non-servicable. Should your Power Pack need to be replaced contact your local approved service centre or dealer who will replace your old Power Pack with a genuine Flymo replacement Power Pack.

Winter Storage

- Fully charge for 24 hours before winter storage.
- If you are unable to leave your Power Pack on permanent charge, re-charge the Power Pack every 3 to 4 months for a full 24 hour charging period to top up the Power Pack charge during winter storage.
- Avoid extended storage without re-charge.
- Store in a cool dry place.

For further information on Power Pack replacement contact Husqvarna Outdoor Products Customer Service direct:-

Telephone : 01325 300303
Fax : 01325 318193

Fitting the Battery Charger and Charging the Power Pack

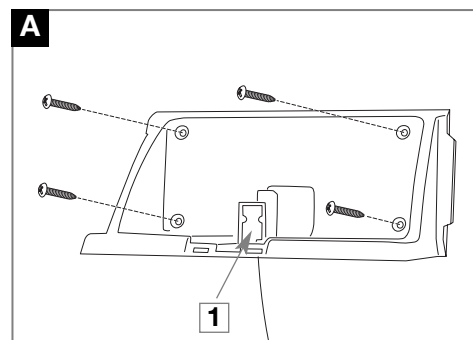

- Attach the Power Pack charger bracket to the wall using the four screws provided (A)
- IMPORTANT!**
Switch charger off at the socket before connecting or disconnecting the Power Pack to the charger bracket

Initial Charging Procedure

- The Power Pack should be charged for 24 hours before use.
- Re-charge your Power Pack immediately after every use for the full 24 hour charging period.
- The Power Pack can be left connected to the charger permanently, with the charger switched on, without fear of overcharging.
- The charger will automatically keep the Power Pack topped up with charge during storage and will ensure that the Power Pack is ready for use.

- Use the charger indoors only.
- Ensure the charger is not exposed to moisture. Keep the charger and Power Pack dry at all times. Keep the charger well ventilated during charging.
- Ensure the Power Pack is correctly located into the bracket (B) and the charge connector (A1).
- Plug the charger into a suitable household electrical socket and switch on.(B1)
- The indicator lamp glows continuously during charging.
- Full charge will be achieved in 24 hours. During charging the charger becomes warm. This is normal and means the charger is operating correctly.

Re-Charging Your Power Pack

- Re-charge the Power Pack as soon as the cutting power of your product begins to die and slow down.
- Avoid running the cordless product into "deep" discharge, i.e. avoid flattening the Power Pack completely.
- Follow the procedure outlined in the **Initial Charging Procedure**.
- Charging the Power Pack according to these instructions should ensure maximum battery life.

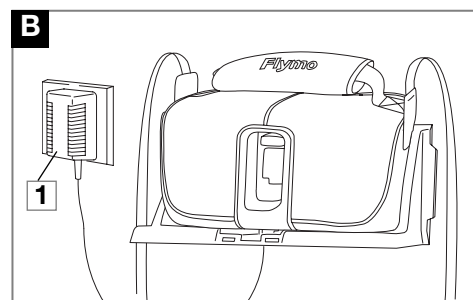

Storing the Sabre Handle

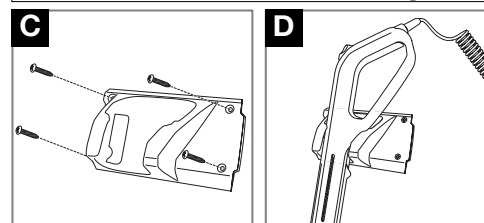

Storing the Sabre Handle

- Attach the Sabre Handle Storage Holder to the wall with the two screws provided (C)
- Store the Sabre Handle in the holder as illustrated in Fig D

Environmental Information

Husqvarna Outdoor Products are manufactured under an Environmental Management System (ISO 14001) using, where practical, components manufactured in the most environmentally responsible manner, according to company procedures, and with the potential for recycling at the end of the products' life.

- Packaging is recyclable and plastic components have been labelled (where practical) for categorised recycling.
- Awareness of the environment must be considered when disposing of 'end-of-life' product.
- If necessary, contact your local authority for disposal information.

BATTERY DISPOSAL

- The battery should be taken to an Approved Service Centre or your local Recycling Station.
- Do NOT dispose of used battery with household waste
- Do NOT dispose of battery to water.
- Lead/Acid batteries can be harmful and should be dis-

posed of through the recognised recycling facility in accordance with European Regulation

- Do NOT incinerate

The symbol on the product or on its packaging indicates that this product may not be treated as household waste. Instead it shall be handed over to the applicable collection point for the recycling of electrical and electronic equipment.

By ensuring this product is disposed of correctly, you will help prevent potential negative consequences for the environment and human health, which could otherwise be caused by inappropriate waste handling of this product. For more detailed information about recycling of this product, please contact your local council office, your household waste disposal service or the shop where you purchased the product.